

- In addition to routine checks for each use, PPE should regularly undergo a detailed inspection by a competent person. Petzl recommends an inspection every 12 months and after any exceptional event in the life of the product.
  - PPE inspection should be conducted with the manufacturer's Instructions for Use.
- Download the instructions at [PETZL.COM](https://www.petzl.com).

## HELMETS



### 1. Known product history

Any PPE showing unexpected degradation should be quarantined, pending a detailed inspection.

The user should:

- Provide precise information on the usage conditions.
- Report any exceptional event regarding his PPE.  
(Examples: fall or fall arrest, use or storage at extreme temperatures, modification outside manufacturer's facilities...).

### 2. Preliminary observations

Verify the presence and legibility of the serial number and the CE mark.  
 Verify that the product lifetime has not been exceeded.  
 Compare with a new device to verify there are no modifications or missing parts.

### 3. Checking the shell

- Check the condition of the outside of the shell (marks, impacts, deformation, cracks, burns, wear, signs of chemical products...).

- Check the condition of the inside of the shell (marks, deformation, cracks, missing parts...). **WARNING:** do not remove the liner that is attached to the shell.

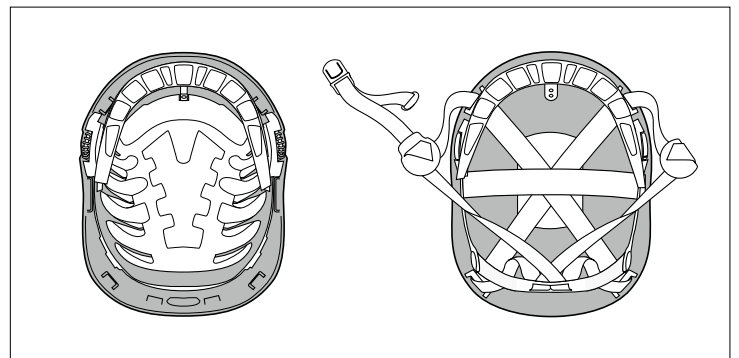
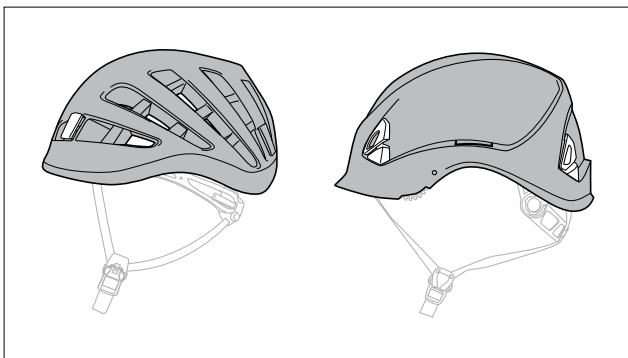

- Remember: personalizing or marking the helmet must not be done with chemical products. Use water-based adhesives for any marking.

- Check the condition of the slots and holes for mounting accessories (deformation, cracks...).

- Check the condition and function of the ventilation shutters (for VERTEX VENT, ELIOS...).

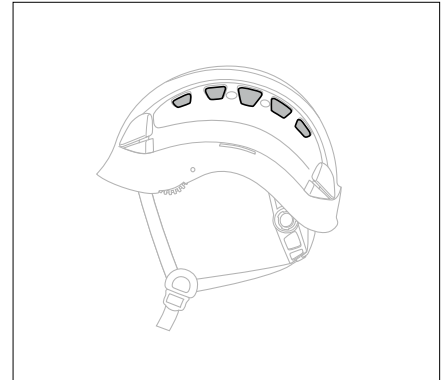
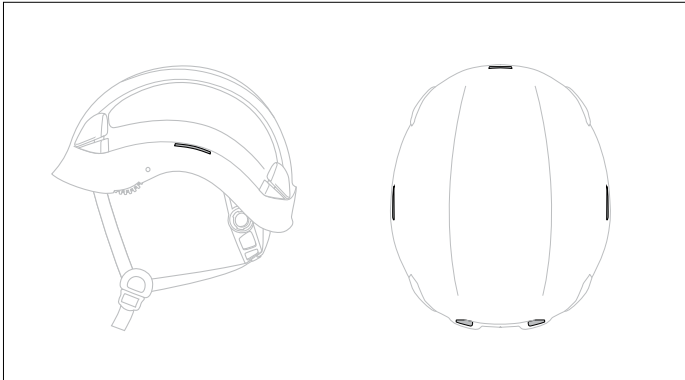

#### 4. Checking the liner

- Check the condition of the liner (marks, deformation, cracks, missing parts...).
- Remove the comfort parts to inspect the hidden areas.  
**WARNING:** do not remove the liner that is attached to the shell.

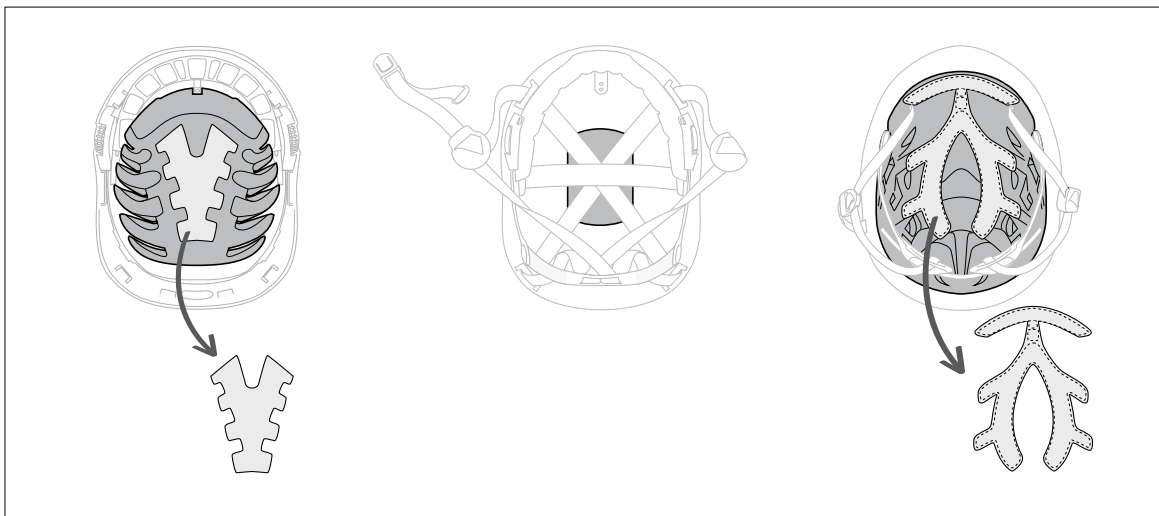

Note: depending on the helmet model, the shell and liner can be:

SIRROCO

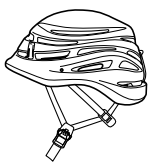

one and the same piece

METEOR



two pieces glued together

VERTEX, ALVEO...



two pieces assembled together

## 5. Checking the cradle (webbing head harness)

- Check the condition of the straps and their attachments to the shell (wear, cuts, burns, deformation of plastic pieces).

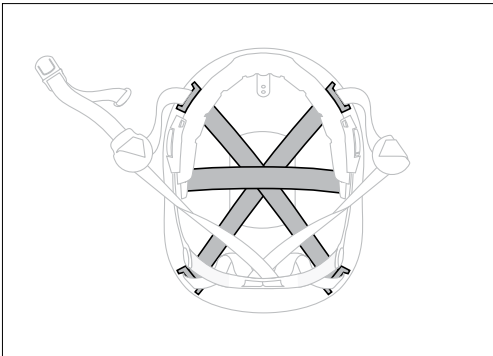

Note: most helmets that have a liner do not have a webbing harness.

## 6. Checking the headband

- Check the condition of the headband and its attachments to the shell (wear, deformation, missing parts...).
- If necessary, remove the foams or comfort parts to inspect the hidden areas.

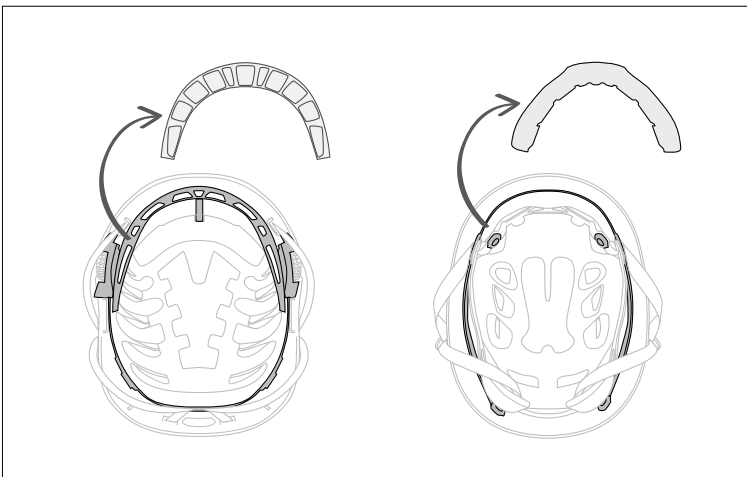

Note: certain helmets such as the METEOR or the SIROCCO have no headband.

## 7. Checking the adjustment system

- Check the condition of the adjustment system and its attachments to the shell (wear, deformation, missing parts...).

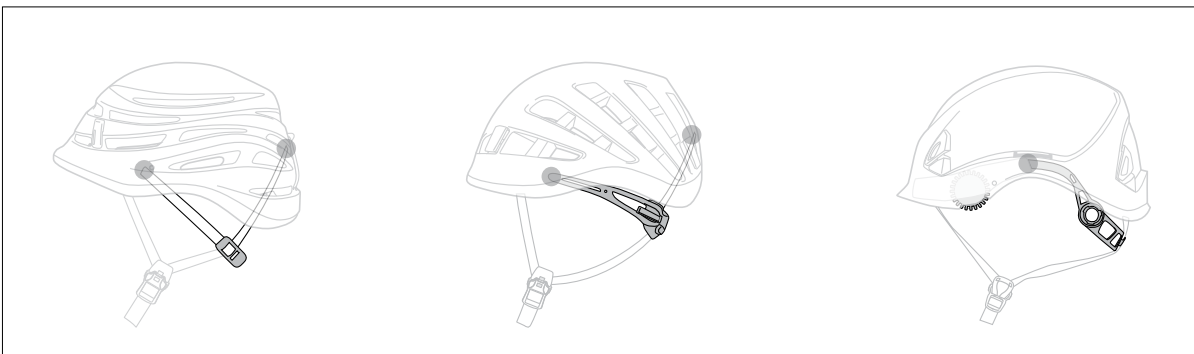

- Check the function of the adjustment system.

Operate the adjustment system in both directions. Pull on the system to verify that it does not lose its adjustment setting.

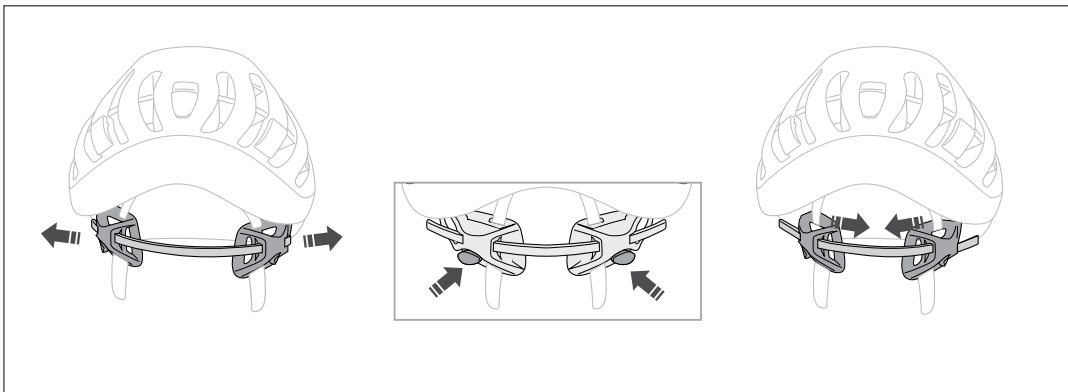
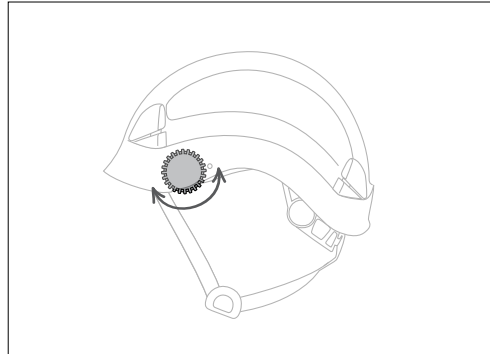
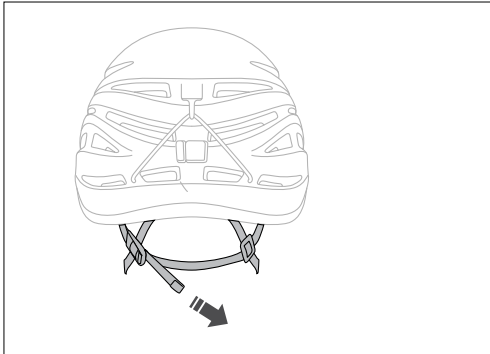

## 8. Checking the chin strap

- Check the condition of the chin strap and the adjustment parts (wear, cuts, burns, deformation of plastic pieces). Move the keepers and plastic pieces to inspect any hidden areas on the straps.

- Check the condition of the chin strap buckle (wear, deformation, breakage). Test the reliability of the fastening by pulling gently on the chin strap.

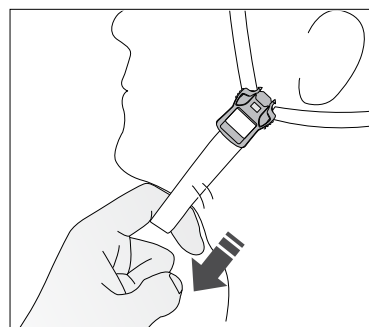
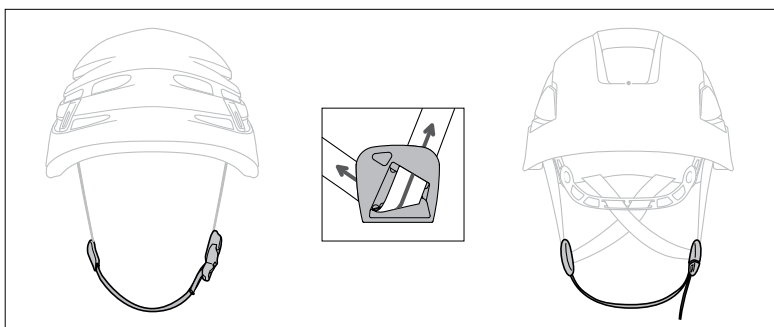

## 9. Checking the comfort foams

- Check the condition of the comfort foams. If necessary, remove them for washing or replacement.



## 10. Checking the headlamp clips

- Check the condition of the headlamp clips (wear, deformation, missing parts...).

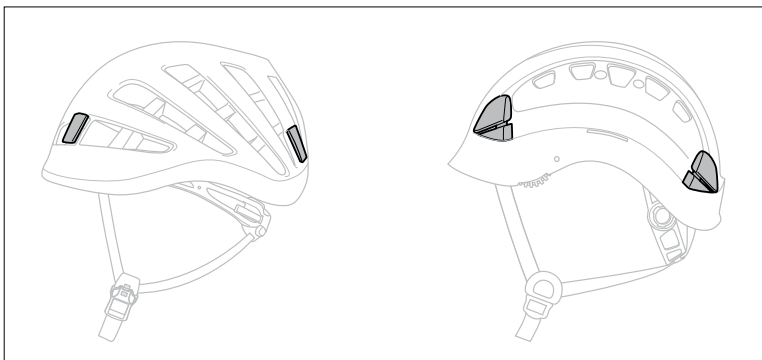

## 11. Checking accessories

- If accessories are mounted on the helmet, check their condition and make sure they are working properly (face shield, headlamp...).

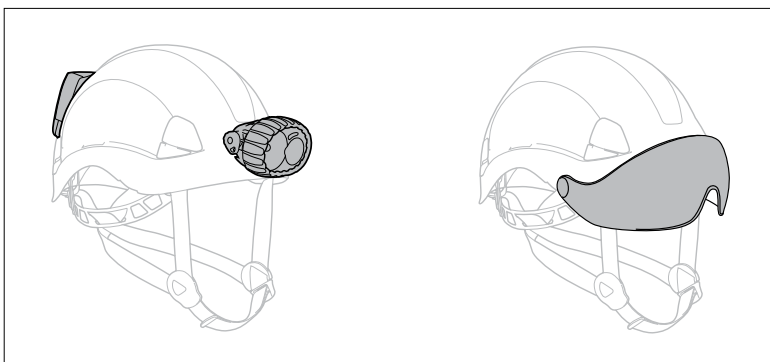

**Appendix 1. Examples of helmets that are worn out, or that should be retired**

• Broken buckle



• Broken buckle



• Broken buckle



• Impact on the shell

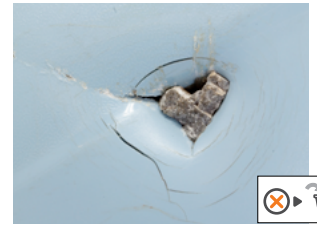

• Chemical product on the shell



• Chemical product on the shell



• Deep scratch on the shell

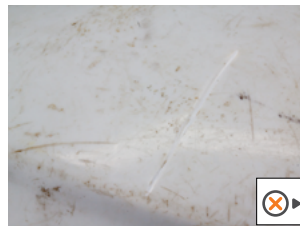

• Marks on the shell and broken clip

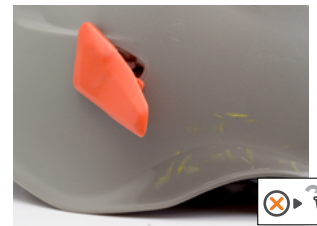

• Cracked liner



• Cracked liner



• Cracked liner



• Liner marked and deformed



• Cracked shell



• Cracked shell



• Cracked shell



• Broken adjustment system



• Deformed shell



• Deformed shell



• Deformed shell



• Impact on the shell



• Worn out comfort foam

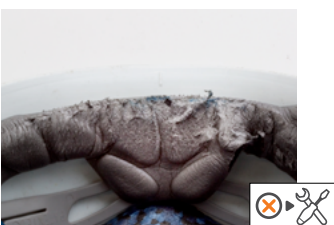

• Torn comfort foam

